

Ice Cuber 46kg/24h with 25kg bin - Air cooled, Self-contained (42gr cube)

ITEM # _____

MODEL # _____

NAME # _____

SIS # _____

AIA # _____

730161 (FGC46AS42)

 Ice Maker, 42gr cube,
 46kg/24h, self-contained,
 25kg ice collection bin
 included, air-cooled

Short Form Specification

Item No. _____

Plastic flap on the front, top and sides in ABS. The ice-making method (spray layering) guarantees compact, hygienically pure ice cubes (42g) that are resistant to melting. The metal sprayers are easy to take away, permit a simple flowing and prevent limestone formation. R452A refrigerant. Container capacity Kg: 25.

Main Features

- Compliant to CE requirements for safety.
- Fully automatic in operation.
- Operates over a wide range of temperatures.
- Suitable for gravity drain only.
- Rated output is at an ambient air temperature of 21°C and water supply temperature of 15°C.
- The ice-making method (spray layering) guarantees crystalline, compact, hygienically pure ice cubes that are resistant to melting.
- Model available in air-cooled version.
- Ice cube cone shape with the trunk sides slightly squashed.
- Bin integrated as standard.
- Compact dimensions of the ice cubers make them highly suitable for any location, particularly those where space is at a premium.

Construction

- Plug as standard (schuko type).
- AISI 304 stainless steel exterior.
- Stainless steel spray arms removable without the use of tools.
- The sprayers are easy to take away, permit a simple flowing and prevent limestone formation.
- Internal ice cubes container in ABS.
- Adjustable feet 110-150 mm.
- Reliability guaranteed by the quality of the construction materials used (plastic flap on the front, top and sides in 304 AISI stainless steel) and the sophisticated product and process technology involved.
- Environmentally friendly: R452a as refrigerant gas.

APPROVAL: _____

Side

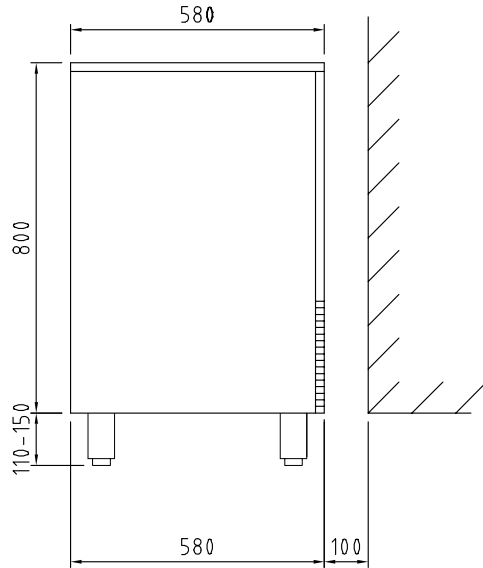

Top

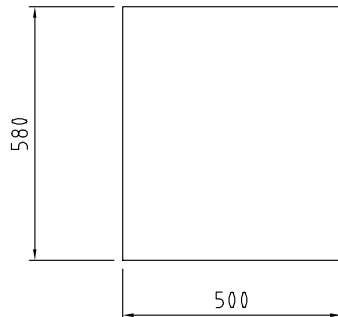

CWI1 = Cold Water inlet 1 (cleaning)
 D = Drain
 EI = Electrical inlet (power)

Front

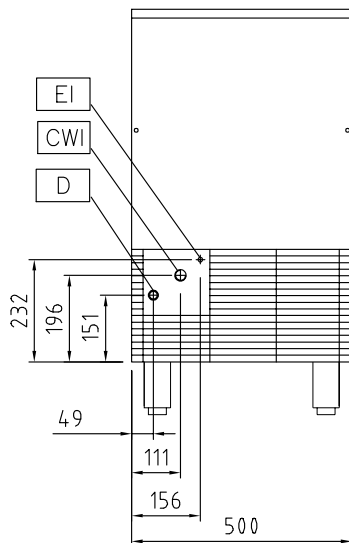

Electric

Supply voltage:

730161 (FGC46AS42) 220-240 V/1N ph/50 Hz

Electrical power max.:

0.5 kW

Capacity:

Bin capacity:

25 kg

Key Information:

External dimensions, Width: 500 mm

External dimensions, Depth: 580 mm

External dimensions, Height: 800 mm

Net weight: 56 kg

Output: 46 kg/day

Kind of cube: Ice Cube 42 g

Sustainability

Refrigerant type:

R452A